

Analysis of the Influence of Tooth Line Radius on the Bending Strength of Circular-Arc-Tooth- Trace Cylindrical Gear

Tang Rui*, Ling Yun

Aviation Engineering Institute, Civil Aviation Flight University of China, Guanghan, China

Email address:

pzhutr@163.com (Tang Rui)

*Corresponding author

To cite this article:

Tang Rui, Ling Yun. Analysis of the Influence of Tooth Line Radius on the Bending Strength of Circular-Arc-Tooth- Trace Cylindrical Gear. *Applied Engineering*. Vol. 4, No. 2, 2020, pp. 55-62. doi: 10.11648/j.ae.20200402.15

Received: April 14, 2020; **Accepted:** May 6, 2020; **Published:** October 30, 2020

Abstract: Research analysis of circular-arc-tooth-trace cylindrical gear transmission line deputy basic forming theory, the use of finite element discretization process to the entire gear model is simplified to only a single tooth model, using software ANSYS Workbench 13.0, reasonable determination of the boundary of model boundary width and depth, based on the Gleason cutter machining parameters, in UG/Open Grip environment, expand the influence of the bending strength of gear tooth line radius mechanism research, obtained under the pressure of a certain intensity, given the corresponding modulus, tooth number, pressure Angle, the parameters of the tooth width conditions, different change with the radius of tooth line, Finally, it is concluded that the bending strength of gear teeth changes with the change of tooth radius. Research has shown that lines to circular arc tooth cylindrical gear teeth, radius and its tooth bending strength have close relations, but not to say that the smaller the radius of the tooth trace of gear tooth, or, the greater the the tooth bending strength is better, but under the condition of a module, tooth line radius within a certain range, the bending strength of gear teeth.

Keywords: Circular-Arc-Tooth-Trace Cylindrical Gear, Model Simplification, Bending Strength, Meshing Performance

1. Introduction

As a new type of gear, circular tooth line cylindrical gear has good meshing performance, contact line length, large coincidence degree, no axial component force, large bearing capacity, high transmission efficiency, smooth transmission and other characteristics [1]. Its tooth profile is a section of circular arc, the tooth width of the central section of the tooth profile is involute tooth shape, while the other section of the tooth profile are elliptic curve family of envelope, namely the envelope of hyperbola. The gear has the characteristics of contact line length, axial force offset and symmetrical arch. In most engineering applications, it can replace the use of spur gear, helical gear and herringbone gear, and its comprehensive performance is better than the latter three, with a broad application prospect [2].

2. The Basic Theory of Arc-Tooth-Trace Cylindrical Gear

2.1. Basic Shape of Arc-Tooth-Trace Cylindrical Gear

In 1926, e. weildhaber of the United States put forward the idea of replacing the involute tooth profile with the circular tooth profile. In 1956, the former Soviet union, he (m. JI. H o kind guide и seem o kind guide) invented the circular-arc gear. After that, Hyperbolic conical gear, circular tooth line conical gear, circular tooth line cylindrical gear were developed. The cylindrical gear with circular tooth lines is studied in this paper. The tooth shape of this gear on the middle section of tooth width is involute, while on the other sections of tooth width, it is the envelope of hyperbolic family [3-6]. Circular tooth line cylindrical gear is shown in figure 1 below.



(a) Three-dimensional model

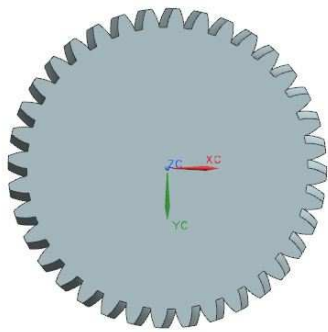

(b) Tooth-width middle section tooth shape

Figure 1. Circular-Arc-Tooth-Trace cylindrical gear.

2.2. Basic Gear Rack of Arc-Tooth-Trace Cylindrical Gear

In general, the basic rack is the basis for studying the gear meshing and cutting mechanism of gear cutter. as shown in the following figure 2 (a) below, The concave and convex tooth surfaces of the rack p and q are respectively, They are equal to the Angle of the cone, the position of the cone is opposite, the two axes are parallel and the distance is half of the tooth distance $t/2 = \pi m / 2$, A part of the sum of two conical surfaces p and q , Here, the top angles of both cones are $\alpha = 20^\circ$.

2.3. Determine the Risk Section of the Gear

To ensure the normal operation of the gear drive, failure is not allowed in its working process. In order to prevent gear tooth fracture, it is necessary to check the bending strength of gear teeth to ensure that the bending stress at the tooth root is lower than the allowable bending stress of gear [7]. At present, there are mainly three methods to analyze the dangerous section of gear tooth, which are flat section method, folded section method and cantilever plate method. Its detailed introduction is as follows [8].

When w. Lewis proposed a method for calculating the bending strength of gear teeth, he treated the gear teeth as parabolic cantilever beam, and took the bending stress of the parabolic beam as the bending stress of the tooth root of the gear teeth. As shown in figure 2 (b), the section BC is the dangerous section.

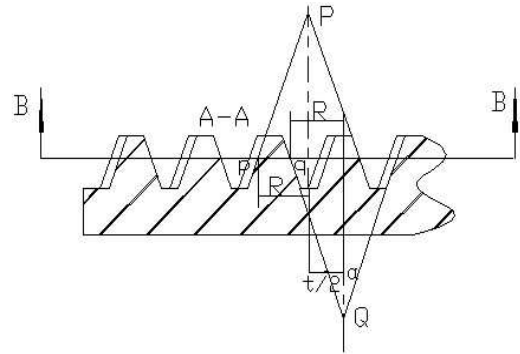

(a)

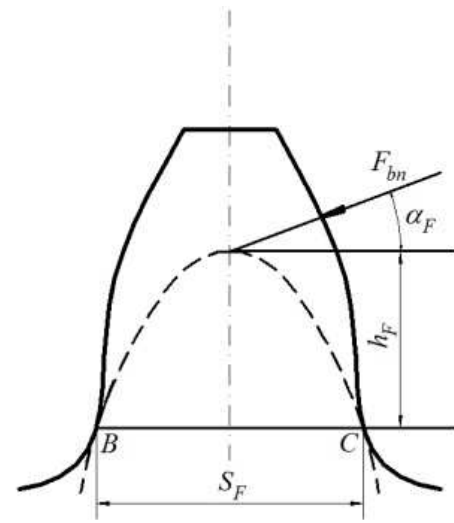

(b)

Figure 2. Basic arc tooth line rack and cross section

3. Analysis of Bending Strength of Arc-Tooth-Trace Cylindrical Gear

3.1. Model Simplification of Arc-Tooth-Trace Cylindrical Gear

The tooth direction line of circular tooth line of cylindrical gear is a section of circular arc, so the tooth shape is relatively complex. When the mesh is generated by discretization, the number of grids and nodes will be relatively complex, while the bending stress of the gear can be analyzed only by a single tooth. For this reason, we only need to simplify the entire gear model to a single-tooth model, which can improve the calculation and processing speed of ANSYS Workbench without affecting the accuracy of the analysis results. The next step is to explain the boundary range selection principle to be followed when simplifying the model. Without affecting the accuracy of the analysis results, the next step is to explain the boundary range selection principle to be followed when simplifying the model.

Generally, the boundary of the analysis model can be taken as [9]: boundary depth PQ, boundary width PS, $PQ \geq 1.5m$;

$PS \geq 6m$. According to the above boundary range division principle, UG NX8.0 is used to segment the three-dimensional model of circular arc gear line cylindrical gear, leaving only one gear tooth, as shown in figure 3 (a) below. Because the bending stress analysis model of circular circular tooth line cylindrical gear in this paper is small in size and simple in structure, the whole mesh is divided automatically first, and then the tooth root which needs to be paid attention to is carried out. The mesh refinement operation is shown in figure 3 (b). Suppose the gear module $m=5$, the number of teeth $z=36$.

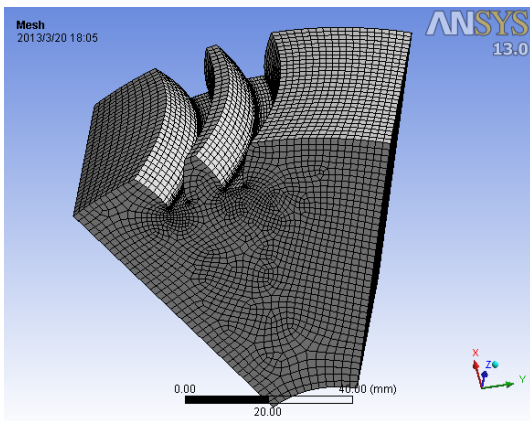
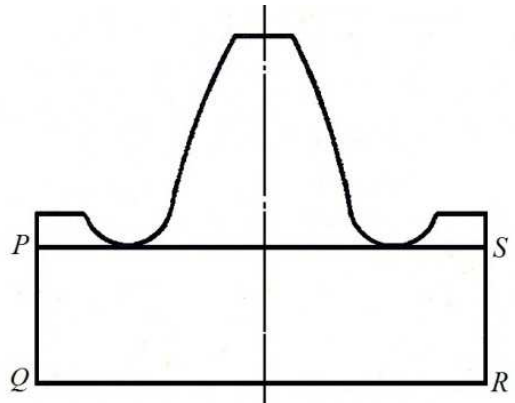

Figure 3. Boundary range division and grid division.

Tooth width $b=50$, tooth line radius= 63.5mm before and after treatment of circular tooth line cylindrical gear. The conclusion that the degree performance is better than that of spur and helical gear confirms the previous theoretical hypothesis. The results are shown in figure 4 below.

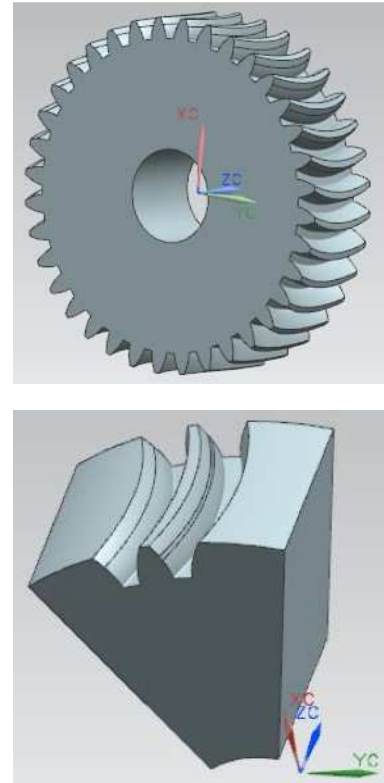

Figure 4. Model segmentation in UG NX.

3.2. Influence of Tooth Line Radius on Bending Strength of Circular Tooth Line Cylindrical Gear

Lines to circular arc tooth cylindrical gear tooth to for a period of circular arc, in theory, the ordinary spur gears can be regarded as when tooth line radius of circular arc tooth cylindrical gears, is to explore more processing method is to use the knife dish milling shape, under this kind of machining method, the knife dish of nominal diameter is directly related to the radius of the tooth gear machining line. Many scholars used the existing gleason cutter disc as the processing tool when discussing the processing method. Therefore, in the following research, the influence mechanism of the radius of the expanded tooth line on the bending strength of the gear will be based on gleason's cutter plate parameters. In this section, 8 gears with module= 5 , tooth number= 36 , tooth width= 50mm , pressure Angle= 20° , and tooth line radius were selected as the research model. The specific parameters are shown in table 1, where the nominal diameter of the cutter disc (that is, the radius of the tooth line is 2 times) is determined by referring to the article "design of curved tooth cylindrical gear" [10].

Table 1. List of gear parameters.

Gear number	1	2	3	4	5	6	7	8
module	5	5	5	5	5	5	5	5
Number of teeth	36	36	36	36	36	36	36	36
tooth width	50	50	50	50	50	50	50	50
Pressure angle	20	20	20	20	20	20	20	20
Nominal diameter of cutter head	89 (3/2")	114.3 (4/2")	127 (5")	152.4 (6")	190.5 (7/2")	228.6 (9")	304.8 (12")	406.4 (16")

Note: in the table, the tooth width and nominal diameter of the cutter disc are mm, the pressure Angle is $^\circ$, and the tooth radius is 1/2 of the nominal diameter of the cutter disc.

In UG NX 8.0, 3d modeling was carried out for these 8 circular circular linear cylindrical gears. Then, following the practice of chapter 4, the Static analysis module [Static Structural] was used to carry out relevant research under the environment of 13.0 of ANSYS Workbench. According to the above theory, the boundary range of the calculation model can be generally taken in the finite element analysis $PQ \geq 1.5m$, $PS \geq 6m$.

Where: PQ is the boundary depth, PS is the boundary width, and m is the gear module. Only one tooth is left. Then ANSYS Workbench 13.0 environment is loaded. In its [Static Structural] module, the properties of gear material no. 45 steel are set as shown in table 2 below:

Table 2. Material roperties of gears.

Materials	Young's Modulus	Poisson's Ratio
45#Steel	2×10^{11} MPa	0.3

In this part of the study, the calculation method of gb3480-83 is adopted, and the load is loaded to the position of the upper boundary point of the meshing area of a single pair, the size is=6000N, and the direction is the normal direction of the position. As for the addition of constraints, mesh division as described above. After analysis, the bending stress distribution diagram of the 8 gears (load distribution at the tooth root after eliminating the stress concentration point) is shown in figure 5 below.

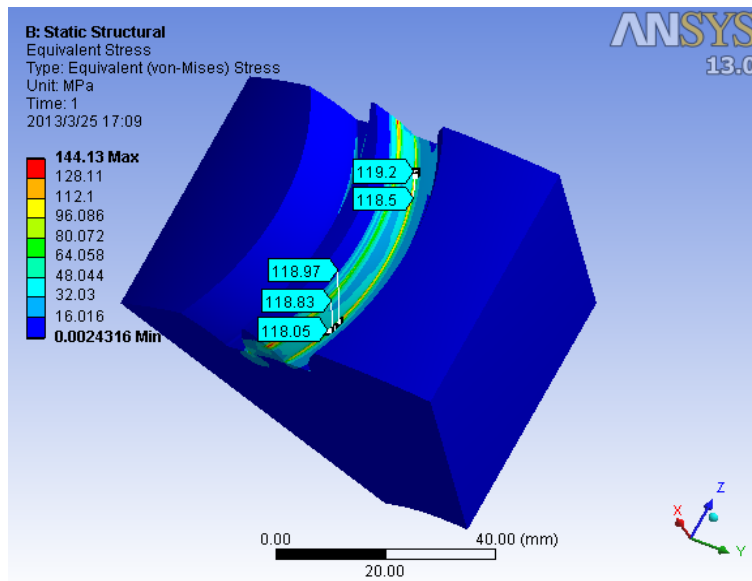

(a)

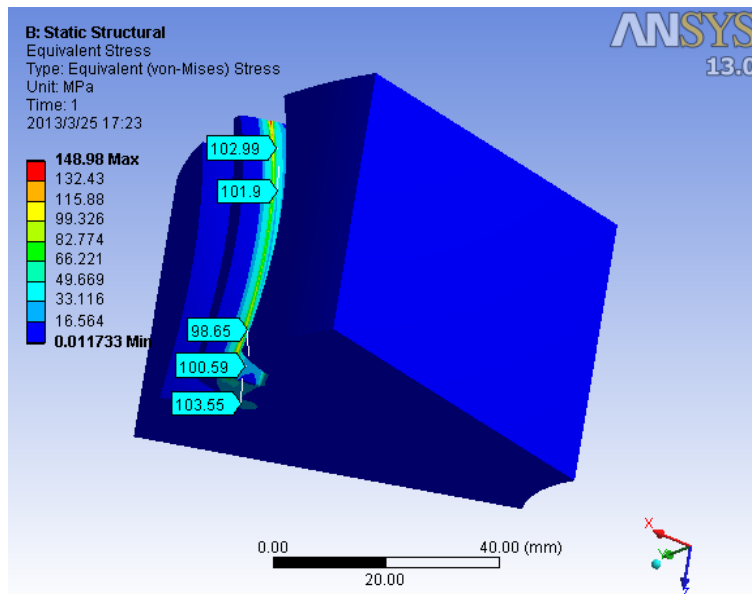

(b)

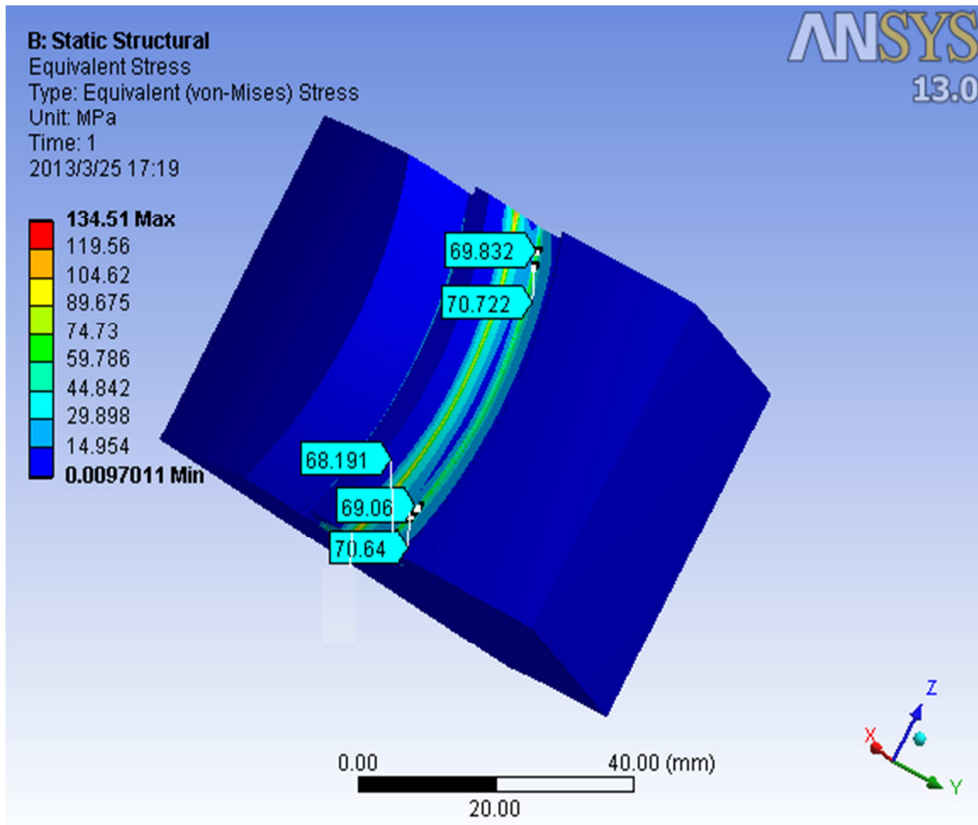

(e)

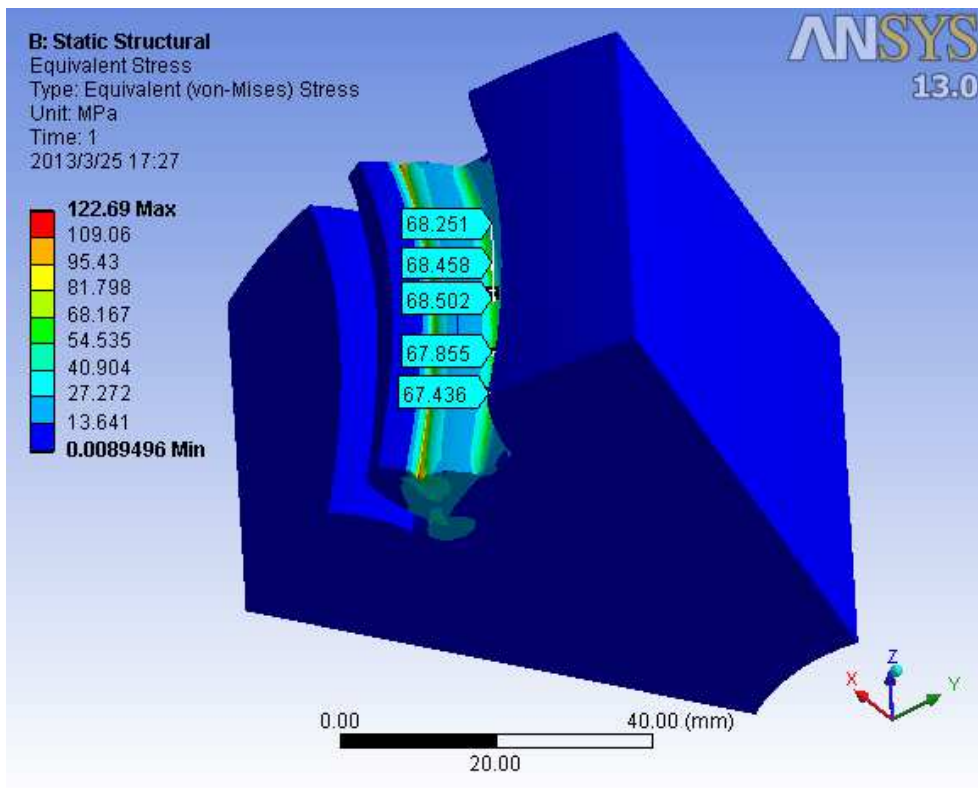

(d)

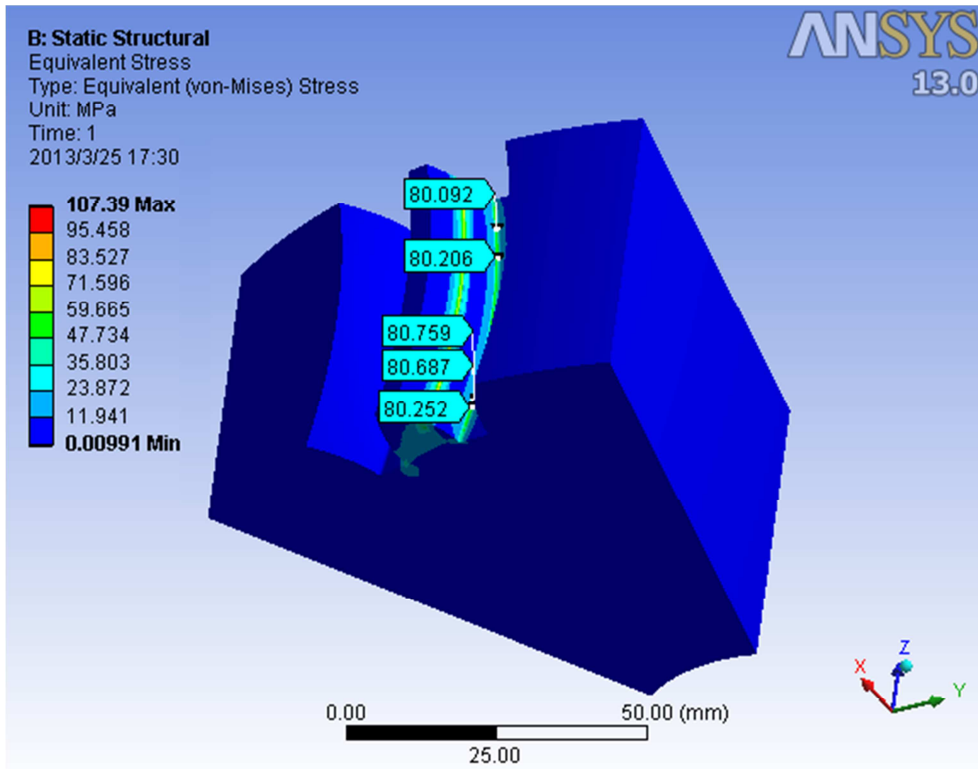

(e)

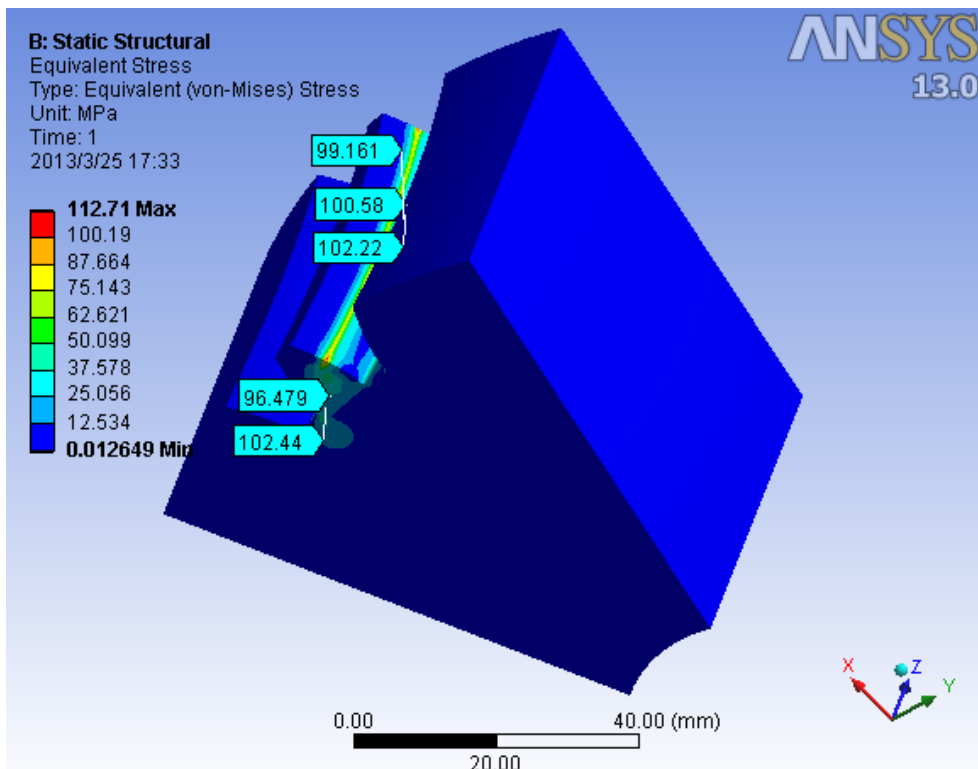

(f)

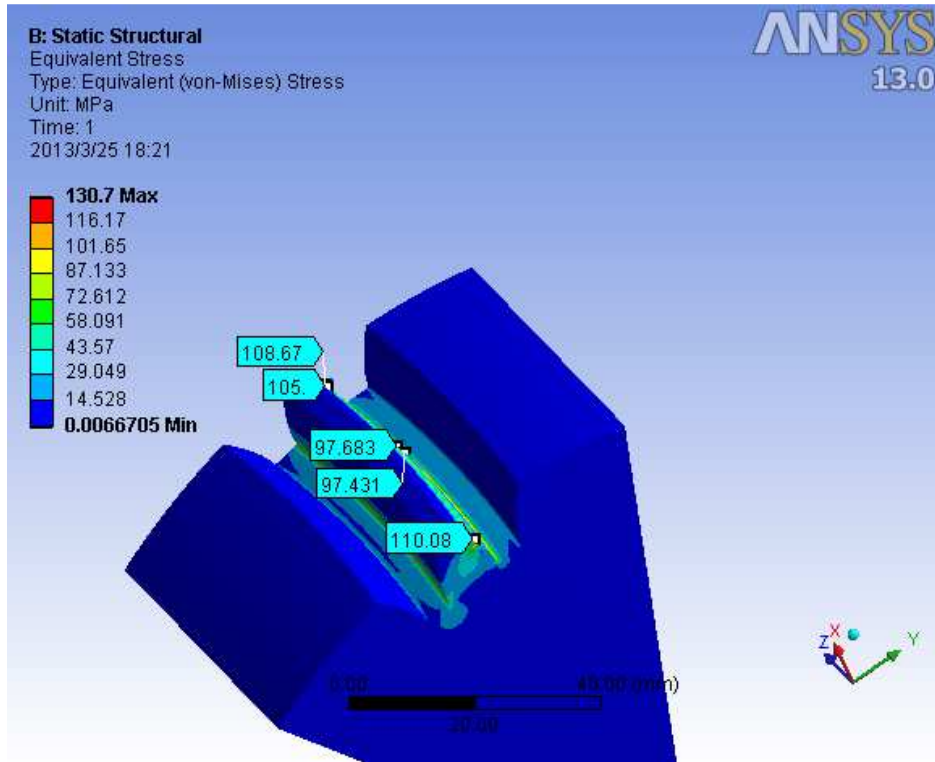

(g)

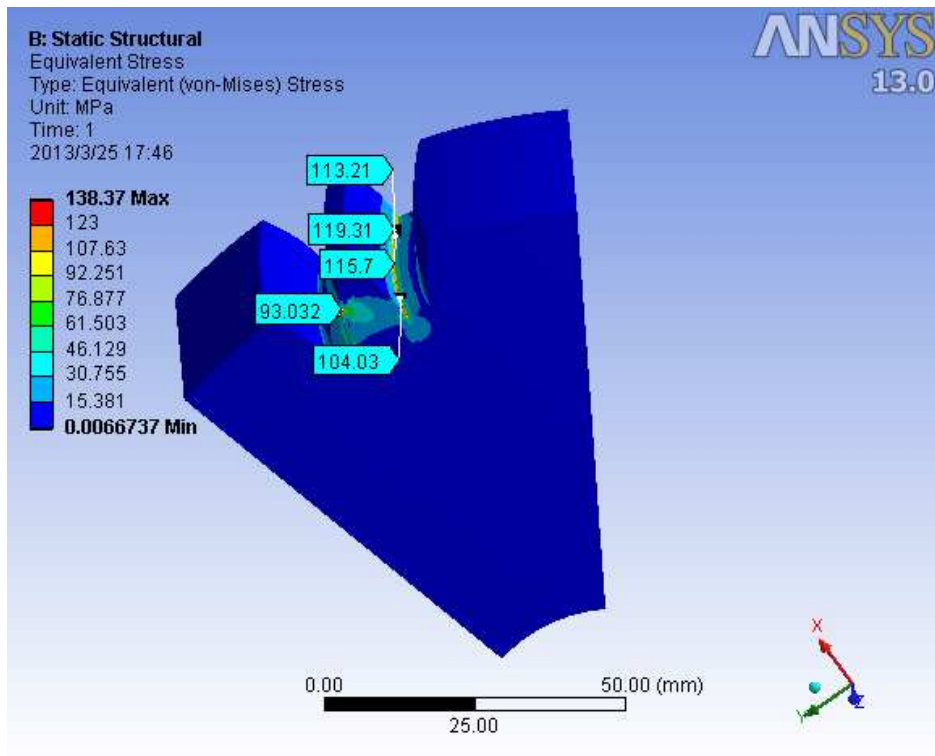

(h)

Figure 5. Bending stress distribution of gear teeth under different tooth line radius.

Figure 5 (a)~(h) correspond to the stress of gear 1~8 respectively. From the figure, we can calculate the stress distribution table of circular circular tooth line cylindrical gear at load=6000N and acting on the position of the upper boundary point of the meshing area of a single pair, as shown in table 3.

Table 3. Bending stress distribution of gear teeth-with varying radius.

Gear number	1	2	3	4	5	6	7	8
Nominal diameter of cutter head	89 (3/2")	114.3 (4/2")	127 (5")	152.4 (6")	190.5 (7/2")	228.6 (9")	304.8 (12")	406.4 (16")
Bending stress value	119.2	103.55	70.72	68.50	80.76	102.44	105.19	119.31

Note: the nominal diameter of the cutter disc in the table is in mm and the stress value in MPa.

4. Conclusions

The bending stress of circular tooth line cylindrical gear under the same load=6000N changes when the other basic parameters remain unchanged, and the tooth line radius r_f changes:

1. When the modulus, the number of teeth, the pressure angle and the tooth width are constant, the bending stress of the teeth first decreases with the increase of the tooth line radius, then reaches the minimum value, and then increases with the increase of the tooth line radius.

2. The tooth line radius of circular tooth line of cylindrical gear is closely related to the bending strength of gear teeth, but it is not that the smaller or larger the tooth line radius of gear teeth is, the better the bending strength of gear teeth will be. According to the analysis, when the modulus=5, the tooth line radius is 63.5mm, 76.2mm, and 95.25mm, that is, when, the bending strength performance is optimal. When the tooth radius is too small (), the tooth of the gear is too bulging, and the tooth bending stress value is close to that of the involute spur gear under the same parameters, which is 119.2mpa. When the tooth line radius is too large (), the tooth shape of the gear teeth is close to that of the spur gear, and its advantage cannot be reflected. The tooth bending stress value of the gear teeth is also close to that of the involute spur gear under the same parameters, which is 119.31 MPa.

Acknowledgements

The authors acknowledge the supports of the 2020 general project from Civil Aviation Flight University of China (No: 2020-048).

References

- [1] Sun xiaowei. Characteristics and machining methods of arc-tooth gear [J]. Mechanical engineer, 1999 (8): 22-22.
- [2] Song aiping, wu weiwei, noble, gao wenjie. Ideal geometric parameters and machining method of cylindrical gear with arc teeth [J]. Journal of Shanghai jiao tong university, 2010, 44 (12). 1735-1740.
- [3] F. I. Litvin. Gear Geometry and Applied Theory [M]. Shanghai: Shanghai science and technology press, 2008.
- [4] Xu d x, pan J s. design of cylindrical gear with curved teeth [J]. Mining machinery, 1990 (9): 49-52.
- [5] Li f s, Lin z g, Yin z f. design of non-circular gears and special gears [M]. Beijing: China machine press, 1983 (8): 226-240.
- [6] Koga Tamotsu. Method for Cutting Paired Gears having Arcuate Tooth Trace [P]. American: US003915060, 1975.
- [7] Zhu xiaolu, e zhongkai, CAI chunyan et al. Analysis of gear bearing capacity [M]. Beijing: higher education press, 1992 (8): 191-203.
- [8] Wu weiwei, song aiping, wang zhaolei. Analysis of tooth root stress of involute cylindrical gear [J]. Mechanical design and manufacturing, 2009 (11): 228
- [9] Zou min. Parameter calculation and selection of circular circular gear [J]. Mechanical design and research, 2000, 2: 36-38.
- [10] Tang jin-yuan, Chen xing-ming, luo cai-wang. Contact analysis of cylindrical gear considering tooth modification and installation error [J]. Journal of central south university (natural science edition), 2012, 43 (5): 1703-1709.